

GENERAL INFORMATION

For the assembly of apparatus and equipment made of borosilicate glass 3.3 a variable framework structural system is available. The basic components of this system are galvanised steel or stainless steel tubes of different diameter as well as structure fittings in different designs and in the corresponding sizes, which are used to join the tubes together. The fittings are available in closed as well as in open design for easier installation later on. The advantages of the framework structural system are its high flexibility, low weight, easy assembly and extendibility.

The following table shows the standard sizes of structure tubing which can be delivered in galvanised steel, stainless steel and blue lacquer and gives an overview of the nomenclature.

Size	Exterior pipe diameter [mm]	Fitting number	Available in galvanised steel	Available in stainless steel	Available in blue lacquer
¾"	26.9	5	yes	yes	yes
1"	33.7	6	yes	yes	yes
1 ¼"	42.4	7	yes	yes	yes
1 ½"	48.3	8	yes	tubes only	on request
2"	60.3	9	yes	tubes only	on request

For special applications other materials, such as for example structure tubing and fittings made of fibre-glass or with an acid-resistant coating, can be used. Our specialist department would be glad to advise you on this.



The structure fittings are used to attach the mounting equipment for the glass components and apparatus, such as support rings, pipe supports, support brackets or pipe clamps, as anchor and expansion points.

The entire selection of standard deliverable components is described on the following pages and an overview is presented in the following figure. In addition, we will be happy to offer special designs on top of the product selection on request.

DESIGN OF TUBULAR STRUCTURES

The recommended measurements for the pipe framework as well as the recommended diameter for tubular piping and fittings depend on the nominal diameter or the diameter and weight of the glass components to be attached.

The figure opposite provides a reference value for which diameter of tubular piping is recommended for a design depending on the forces acting on it and the support spacing.

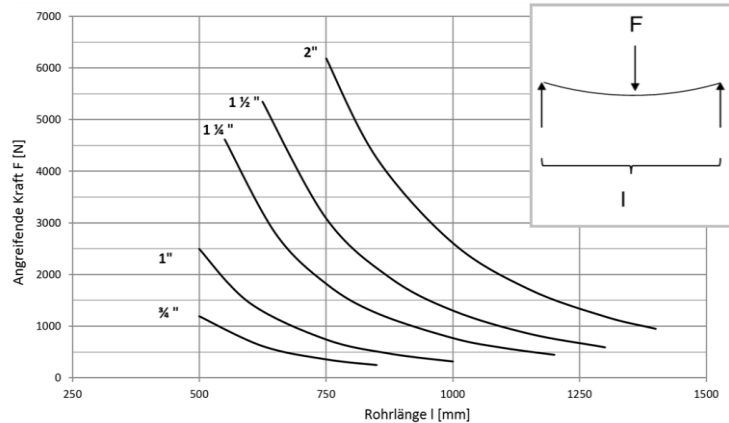

The stability of a tube framework is dependent on diagonal connections in addition to the correct support spacing. For this reason a minimum of two sides arranged at right angles to each other are provided with cross-bracing for rigidity. Additionally, in many cases it is sensible to form a screw connection between the legs of the framework and the floor or a screw connection with a wall or platform, if available.

The assembly of the glass construction should be carried out according to the anchor points provided in the framework. These anchor points should be able to hold the entire weight of the components attached to them. Vessel holders are used as anchor points for spherical vessels and standard cylindrical vessels. Columns can be mounted using their clamp rings by either using tube frameworks or using fittings with bush inserts. Support brackets are available for pipelines.

When mounting anchor and expansion points it must be ensured that borosilicate glass can expand freely. For this reason a decoupling device, for example bellows, should be included between two anchor points.

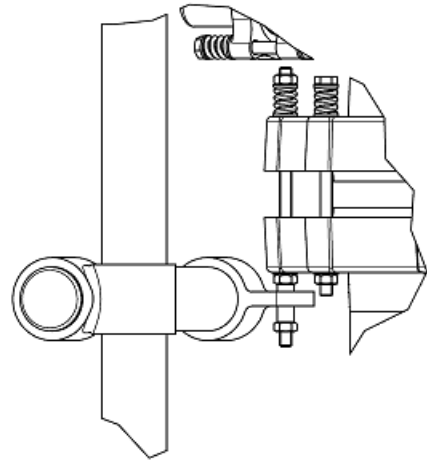

Columns also need to be guided sideways, which can be achieved using an expansion bracket on one of the upper clamp ring couplings (see figure).

Vibrations that can have an effect on glass components by travelling through the tube framework should be prevented using suitable means or detached from them. On request, a verification of earthquake safety in accordance with DIN 4149 can be carried out for the framework or for all apparatus.

Please contact our specialist departments if you have further questions.

GLASS PIPELINE SUPPORT INTERVALS

Pipelines are mounted using pipe supports or pipe clamps. Horizontal as well as vertical pipelines have to be supported at specific distances in order to avoid forces on the pipes due to sag or sideways kinking (for example before and after bellows): The maximum support spacing for horizontal piping is dependent on the weight of the medium and is presented in the following table.

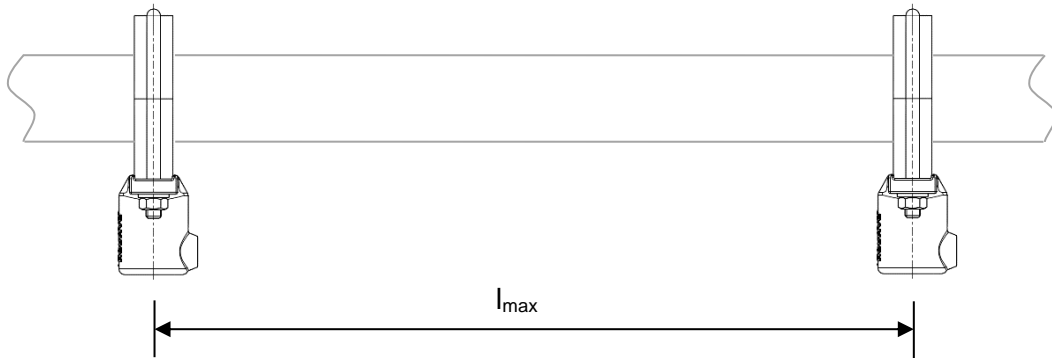

DN pipeline	Maximum support spacing l_{max} for medium [mm]		
	gaseous	liquid $\rho = 1$	liquid $\rho = 1,8$
15	1.500	1.500	1.000
25	2.000	2.000	1.500
40	2.500	2.000	1.500
50	2.500	2.000	1.500
80	3.000	2.000	1.500
100	3.000	2.500	2.000
150	3.000	2.000	2.000
200	3.000	2.000	1.500
225	3.000	2.000	1.500
300	3.000	2.000	1.500

The support spacing for vertical lengths of pipeline should not exceed 5,000 mm.

Floating bearings are the type of pipe support used. Weights of vertical lengths of pipeline are to be secured using anchor points like support brackets.

An overview of the various structure and support items is shown in the following:

Structure fittings:

- Structure fittings, galvanised, closed, type KK..
- Structure fittings, stainless steel, closed, type KKS..
- Structure fittings closed, Typ KKO.../ KKOS...-
- Structure fittings closed, Typ KKO.../ KKOS...-
- Structure bushes, type KKN..M...-

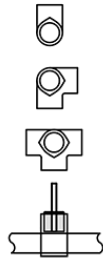

Glass Piping Support:

- Piping Support, galvanised, type KHR..
- Piping Support, stainless steel, type KHRS..
- Pipe hangers, galvanised, type KPC..
- Pipe hangers, stainless steel, type KPCS..
- Support brackets, galvanised, type KHB..
- Support brackets, stainless steel, type KHBS..



Structure tubing:

- Structure tubing, galvanised, type KT..
- Structure tubing, stainless steel, type KTS..
- Tube Plugs type KPT..

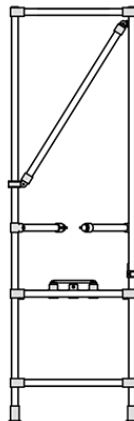

Vessels, columns support :

- Spherical support saddles, type KSR...
- Vessel holders, type KST...
- Angled support brackets , type KSA...
- retaining bracket, type KLL..
- Support plates

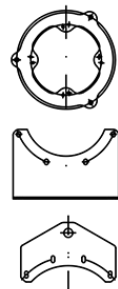

Rolls and bases:

- Apparatus roll, galvanised, type KC..
- Apparatus roll, stainless steel, KCS..
- Heavy-weight roll, type KCH..
- Structure foot TYP KK62-..
- Wall-fixation
- Ceiling-fixation

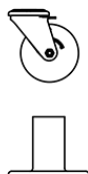

Various:

- Lift-/ lowering-devices
- Makrolon-containment and PVC-matts

STRUCTURE TUBINGS

Standard galvanised steel tubing's are available (type KT), as well as type KTS stainless steel tubes (1.4571) in accordance with DIN EN 10296. The necessary length is selected, as in the following examples, by using a four-digit length unit entered after the item number. The maximal length is 6,000 mm.

Product description:

Tubular piping ¾", stainless steel, length 400 mm

Item number

KTS Ø_{tube} - l_{tube}

Examples

KTS 5-0400

Tubular piping 1 ¼", galvanised steel, length 1,200 mm

KT Ø_{tube} - l_{tube}

KT 7-1200

	Size	Item no.	Item no.
		Galvanised steel	Stainless steel
	¾"	KT 5	KTS 5
	1"	KT 6	KTS 6
	1 ¼"	KT 7	KTS 7
	1 ½"	KT 8	KTS 8
	2"	KT 9	KTS 9

TUBE PLUGS

In order to close frame tubes, the following plastic tube plugs can be ordered.

	Size	Item no.
	¾"	KPT 5
	1"	KPT 6
	1 ¼"	KPT 7
	1 ½"	KPT 8
	2"	KPT 9

STRUCTURE FITTINGS

Structure fittings can be delivered in 3/4" up to 2" in galvanised steel and in stainless steel. There are open fitting types for later installation in existing structures, "KKO..." and "KKSO...". Steel fittings can also optionally be delivered with a blue lacquer, which is to be marked with the code "-C" at the end of the item number.

The fittings are fixed to the tubular piping using hexagon socket head cap screws. The tightening torque of these screws must be 40 Nm in order for the weight forces presented in the figure above in section "design of tubular structures" to apply.

Product description:

Structure fitting, galvanised steel

Item numbertype KKØ_{tube}**Example**

KK 10-6

Structure fitting, blue lacquer



type KKØ_{tube}-C

KK 10-6

Structure fitting, stainless steel

type KKSØ_{tube}

KKS 14-7

Type	Size	Item no.	Item no.	Item no.	Item no.
		Closed Galv. steel	Closed Stainless steel	Open Galv.steel	Open Stainless steel
	3/4"	KK 10-5	KKS 10-5	KKO 10-5	KKSO 10-5
	1"	KK 10-6	KKS 10-6	KKO 10-6	KKSO 10-6
	1 1/4"	KK 10-7	KKS 10-7	KKO 10-7	KKSO 10-7
	1 1/2"	KK 10-8		KKO 10-8	
	2"	KK 10-9		KKO 10-9	
	3/4"	KK 14-5	KKS 14-5		
	1"	KK 14-6	KKS 14-6		
	1 1/4"	KK 14-7	KKS 14-7		
	1 1/2"	KK 14-8			
	2"	KK 14-9			
	3/4"	KK 21-5	KKS 21-5		
	1"	KK 21-6	KKS 21-6		
	1 1/4"	KK 21-7	KKS 21-7		
	1 1/2"	KK 21-8			
	2"	KK 21-9			
	3/4"	KK 26-5	KKS 26-5		
	1"	KK 26-6	KKS 26-6		
	1 1/4"	KK 26-7	KKS 26-7		
	1 1/2"	KK 26-8			
	2"	KK 26-9			
	3/4"	KK 35-5	KKS 35-5		
	1"	KK 35-6	KKS 35-6		
	1 1/4"	KK 35-7	KKS 35-7		
	1 1/2"	KK 35-8			
	2"	KK 35-9			

Type	Size	Item no.		Item no.	
		Closed Galv. steel	Closed Stainless steel	Open Galv. steel	Open Stainless steel
	3/4"	KK 45-5	KKS 45-5	KKO 45-5	KKSO 45-5
	1"	KK 45-6	KKS 45-6		KKSO 45-65
	1 1/4" auf 3/4"			KKO 45-75	KKSO 45-75
	1 1/4"	KK 45-7	KKS 45-7	KKO 45-7	
	1 1/2"	KK 45-8			
	2" auf 3/4"			KKO 45-95	
	2" auf 1 1/4"			KKO 45-97	
	2"	KK 45-9			
	3/4"	KK 49-5	KKS 49-5		
	1"	KK 49-6	KKS 49-6		
	1 1/4"	KK 49-7	KKS 49-7		
	1 1/2"	KK 49-8			
	2"	KK 49-9			
	3/4"	KK 50-5		KKO 50-5	KKSO 50-5
	1"	KK 50-6			KKSO 50-6
	1 1/4"	KK 50-7	KKS 50-7	KKO 50-7	KKSO 50-7
	1 1/2"	KK 50-8			
	2"	KK 50-9		KKO 50-9	
	3/4"	KK 173-5		KKO 173-5	KKSO 173-5
	1"	KK 173-6			KKSO 173-6
	1 1/4"	KK 173-7		KKO 173-7	KKSO 173-7
	1 1/2"	KK 173-8			
	2"	KK 173-9		KKO 173-9	
	3/4"	KK 62-5	KKS 62-5		
	1"	KK 62-6	KKS 62-6		
	1 1/4"	KK 62-7	KKS 62-7		
	1 1/2"	KK 62-8			
	2"	KK 62-9			

CASTORS FOR APPARATUS STRUCTURES

Alternatively to the type KK62-... tubular piping legs, castors are available for mobile apparatus. The castors are connected directly to tubular piping using a bush insert and a structure fitting (type KK(S)14-...), that are included in the delivery. The castor housings are made either from galvanised steel or stainless steel. Standard designs of castors for heavy loads are made out of stainless steel. The wheels have a durable polyurethane wheel tread - optionally in electrically conductive design -, leave no traces, and have a Shore A hardness of 94°. The castors come as swivel castors in standard design, and swivel castors with brakes as well as fixed castors are available as options. It is recommended to use at least two brakes on one mobile framework with four castors.

An electrically conductive variant is available as an option.

Description:	Item number	Examples
Swivel castor, galvanised steel	KC Ø _{tube}	KC 7
Swivel castor, stainless steel	KCS Ø _{tube}	KCS 7
Swivel castor, galvanised steel, with brake	KC Ø _{tube} -O1	KC 7-O1
Fixed castor, galvanised steel	KC Ø _{tube} -O2	KC 7-O2
Swivel castor, galvanised steel, electrically conductive design	KC Ø _{tube} -M1	KC 7-M1

If needed there are also other castor designs available. Please contact our specialist department about this.

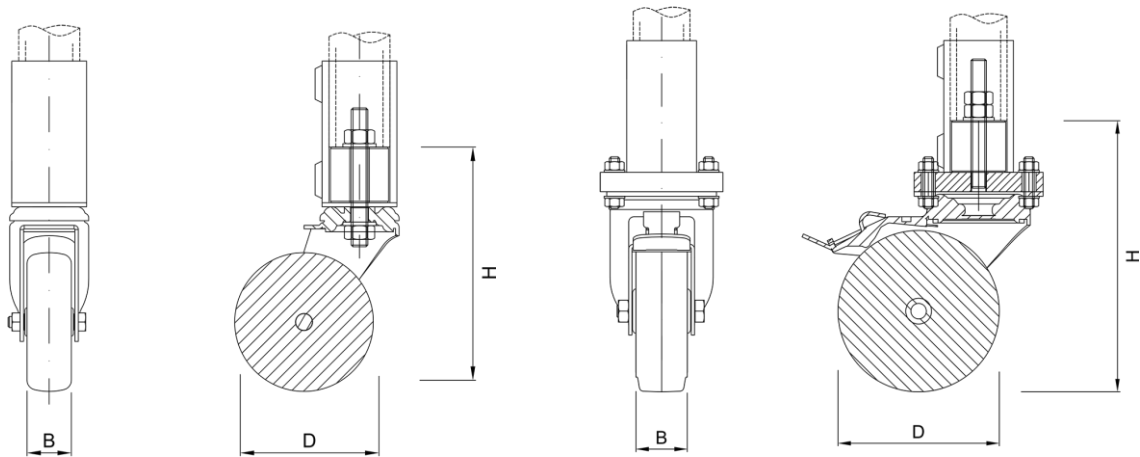

Castors KC../KCS..

castors, heavy duty, KCH 7

	D [mm]	d	B [mm]	H [mm]	Load capacity per steel/stainless steel castor [kg] **	Total load capacity of mobile apparatus* **	Item no. Steel	Item no. Stainless steel
3/4"	100	M12	32	133/125	120/150	360/450	KC 5	KCS 5
1"	100	M12	32	133/125	120/150	360/450	KC 6	KCS 6
1 1/4"	100	M12	32	133/125	120/150	360/450	KC 7	KCS 7
1 1/4"	125	M12	40	150	250	750	-	KCH 7

*when using four castors, safety factor included

**the load capacity is reduced by 35 % when choosing the conductive version

BUSH INSERTS

Bush inserts form a transition between structure fittings and mounting brackets using threaded rods. They are primarily used to join support brackets or flange rings to the basic framework in conjunction with 90° fittings. The bushings are made of stainless steel, and optionally from steel.

Description:

Bush insert, stainless steel

Bush insert, steel

Item number

KKN $\emptyset_{\text{tube}}\text{-M...-H}$

KKN $\emptyset_{\text{tube}}\text{-M...-H -M2}$

Examples

KKN 7-M08-50

KKN 8-M12-50-M2

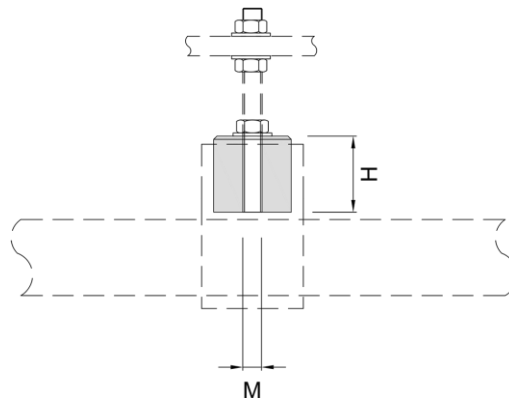

KKN... bush inserts

Size	Thread	H [mm]	Item no.
3/4"	M8	30	KKN 5-M08-30
	M10		KKN 5-M10-30
	M12		KKN 5-M12-30
1"	M8	35	KKN 6-M08-35
	M10		KKN 6-M10-35
	M12		KKN 6-M12-35
1 1/4"	M8	50	KKN 7-M08-50
	M10		KKN 7-M10-50
	M12		KKN 7-M12-50
	M16		KKN 7-M16-50
1 1/2"	M8	50	KKN 8-M08-50
	M10		KKN 8-M10-50
	M12		KKN 8-M12-50
	M16		KKN 8-M16-50
2"	M8	60	KKN 9-M08-60
	M10		KKN 9-M10-60
	M12		KKN 9-M12-60
	M16		KKN 9-M16-60

PIPE SUPPORTS

Pipe supports consist of a two-part rubber insert, a round bracket and a retaining plate with a tubular piping connection. The pipe supports are available in galvanised steel or in stainless steel designs.

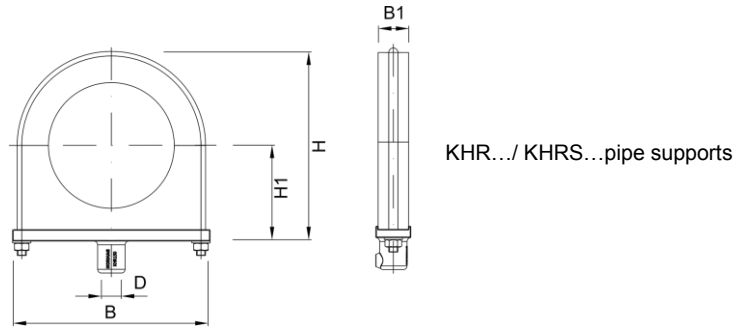

DN	H [mm]	H1 [mm]	B [mm]	B1	D	Item no.	
						Galv. steel	Stainl. steel
15	69	35,5	74	20	¾" / Ø28	KHR 015	KHRS 015
25	69	35,5	74	20	¾" / Ø28	KHR 025	KHRS 025
40	98	50	103	20	¾" / Ø28	KHR 040	KHRS 040
50	98	50	103	20	¾" / Ø28	KHR 050	KHRS 050
80	187	94,5	194	20	¾" / Ø28	KHR 080	KHRS 080
100	187	94,5	194	20	¾" / Ø28	KHR 100	KHRS 100
150	248	125,5	259	40	¾" / Ø28	KHR 150	KHRS 150
200	299	150,5	309	40	1 ¼" / Ø44	KHR 200	KHRS 200

PIPE CLAMPS

Pipe clamps are an alternative to pipe supports. The connection to the tube framework or a wall is achieved by using a threaded rod and not using structure tubes. The pipe clamps are two-part and completely lined inside with rubber padding and available in either galvanised steel or stainless steel.

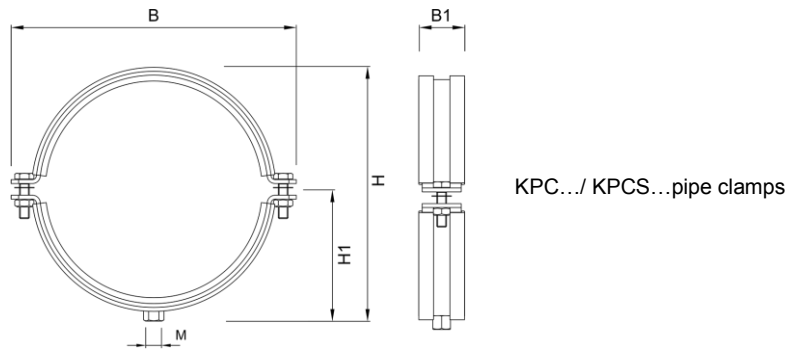

DN	H [mm]	H1 [mm]	B [mm]	B1	M	Item no.	
						Galv. steel	Stainl. steel
15	55	32	70	23	M10	KPC 015	KPCS 015
25	66	38	80	23	M10	KPC 025	KPCS 025
40	83	46	98	23	M12	KPC 040	KPCS 040
50	96	53	111	23	M12	KPC 050	KPCS 050
80	124	65	144	28	M12	KPC 080	KPCS 080
100	154	82	176	28	M12	KPC 100	KPCS 100
150	202	106	226	28	M12	KPC 150	KPCS 150
200	257	135	306	46	M12	KPC 200	KPCS 200
300	350	183	394	46	M12	KPC 300	KPCS 300

SUPPORT BRACKETS

Support brackets are primarily used to secure the weight of vertical pipelines and act as anchor points. In order to avoid tensile strain glass pipelines should be mounted at the lowest point.

The support brackets are provided with several bores or elongated holes for the various pitch circles of PF, KF and KF silumin clamp rings. The nominal diameter 80 can also be ordered for 3/4" instead of for 1 1/4".

Description:

Support bracket, galvanised steel

Support bracket, galvanised steel, 3/4" connection

Item number

KHB DN

KHB DN-O5

Examples

KHB 080

KHB 080-O5

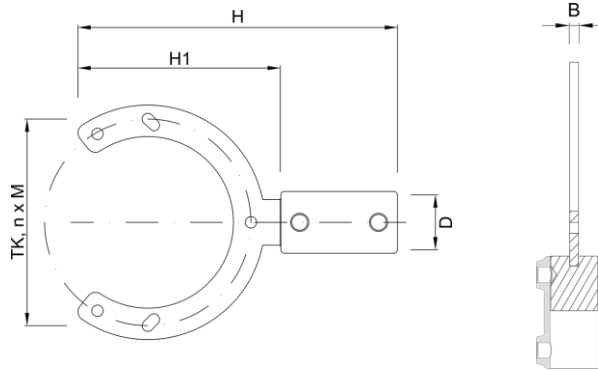

KHB.../ KHBS...support bracket

DN	H [mm]	H1 [mm]	TK [mm]	nxM [mm]	D	Item no. Galv. steel	Item no. Stainl. steel
15	161	69	50 ^{1),2),3)}	3xØ9	3/4"	KHB 015	KHBS 015
			70 ¹⁾	3xØ10			
25	178	86	85 ²⁾	3xØ10	3/4"	KHB 025	KHBS 025
			75 ³⁾	3xØ10			
			86 ¹⁾	3xØ10			
40	198	106	110 ²⁾	3xØ10	3/4"	KHB 040	KHBS 040
			100 ³⁾	3xØ10			
			98 ¹⁾	3xØ10			
50	204	112	125 ²⁾	3xØ10	3/4"	KHB 050	KHBS 050
			110 ³⁾	3xØ10			
			133 ¹⁾	3xØ10			
80	253	161	160 ²⁾	3xØ10	3/4"	KHB 080-O5	KHBS 080-O5
			150 ³⁾	3xØ10			
			133 ¹⁾	3xØ10			
80	262	160	160 ²⁾	3xØ10	1 1/4"	KHB 080	KHBS 080
			150 ³⁾	3xØ10			
			178 ¹⁾	3xØ10			
100	280	177	180 ²⁾	3xØ10	1 1/4"	KHB 100	KHBS 100
			170 ³⁾	3xØ10			
			254 ¹⁾	3xØ10			
150	340	238	240 ²⁾	3xØ10	1 1/4"	KHB 150	KHBS 150
			225 ³⁾	3xØ10			
			295 ^{1), 2)}	3xØ10			
200	310	208	280 ³⁾	3xØ10	1 1/4"	KHB 200	KHBS 200
			400 ^{1), 2)}	3xØ10			
300	363	260	395 ³⁾	3xØ10	1 1/4"	KHB 300	KHBS 300

1) Pitch circle for PF system, 2) Pitch circle for KF system, 3) Pitch circle for silumin flange rings

LOWER SUPPORT RINGS

Lower support rings serve to hold and transfer weight load of vertical pipelines, vessels and apparatus in a tube framework. Fixation to the framework is carried out either by screwing the support rings to flange couplings or by using threaded rods and insert bushes on the outer brackets. Support rings always act as anchor points which should be remembered when carrying out further mounting. A decoupling device, for example bellows, should be included between two anchor points.

Bores for the connection of PF, KF and silumin flange rings are provided.

The support rings can optionally be delivered as part of an installation kit along with the structure fittings, insert bushes and screw fixing for installation into an available tube framework. The size of the structure fittings can be chosen freely.

Description:

- Lower support ring, galvanised steel
- Lower support ring, stainless steel
- Lower support ring, galvanised steel, incl. structure fitting 1 1/2"
- Lower support ring, stainless steel, incl. structure fitting 3/4"

Item number	Examples
KLS DN	KLS 150
KLSS DN	KLSS 150
KLS DN-O3Ø _{tube}	KLS 300-O38
KLSS DN-O3Ø _{tube}	KLSS 150-O35

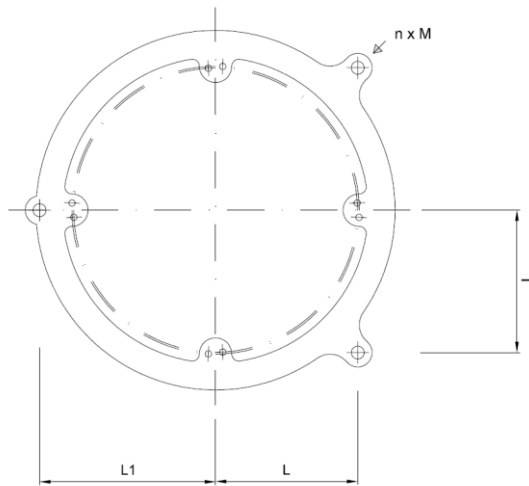

KL.../ KLSS...lower support ring

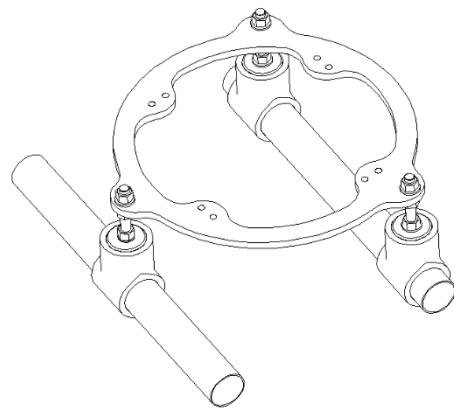

Option incl. structure fittings

for [DN]	L [mm]	L1 [mm]	n x M	Item no.	
				Galv. steel	Stainless steel
80	80	125	3 x Ø14	KLS 080	KLSS 080
100	95	135	3 x Ø14	KLS 100	KLSS 100
150	125	165	3 x Ø14	KLS 150	KLSS 150
200	155	190	3 x Ø14	KLS 200	KLSS 200
300	200	245	3 x Ø18	KLS 300	KLSS 300
400	275	298	3 x Ø18	KLS 400	KLSS 400
450	300	340	3 x Ø18	KLS 450	KLSS 450
600	375	400	3 x Ø18	KLS 600	KLSS 600

SUPPORT RINGS FOR SPHERICAL VESSELS

Support rings are used to hold spherical vessels with a volume of 5 to 20 L. They are made of stainless steel and have a soft insert to protect the spherical vessel. Support rings are connected to the tube framework using three bores and their height is therefore easy to adjust.

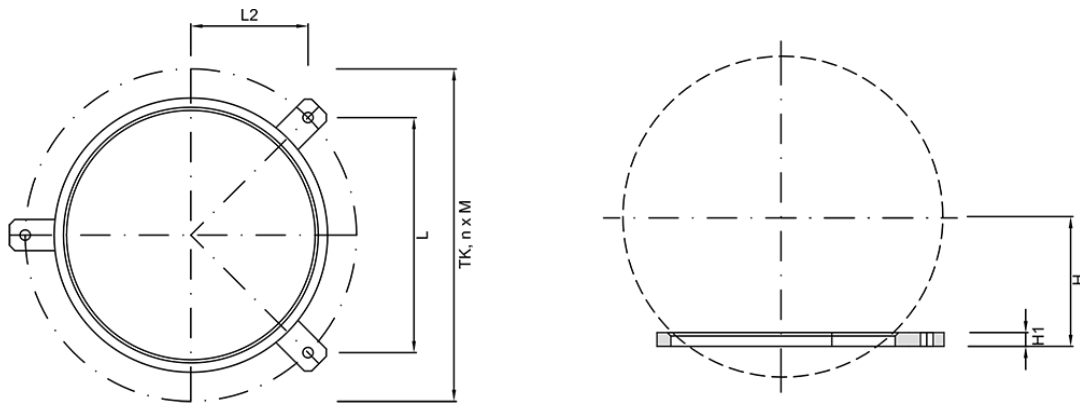

KSR...support rings for spherical vessels

for spherical vessel [l]	L [mm]	L2 [mm]	H [mm]	H1 [mm]	TK [mm]	n x M	Item no.
5	220	56	89	12	230	3 x Ø9	KSR 05
10	220	64	112	12	254	3 x Ø9	KSR 10
20	209	104	125	12	295	3 x Ø9	KSR 20

VESSEL HOLDERS

Vessel holders are used to hold spherical vessels with a volume between 50 and 200 L and for cylindrical vessels with a nominal diameter between 400 and 600. Many sizes can be used for a specific nominal diameter of cylindrical vessel and for a specific size of spherical vessel. Vessel holders have three bores like support rings. They consist of aluminium, have a corrosion-proof coating and are provided with felt inserts.

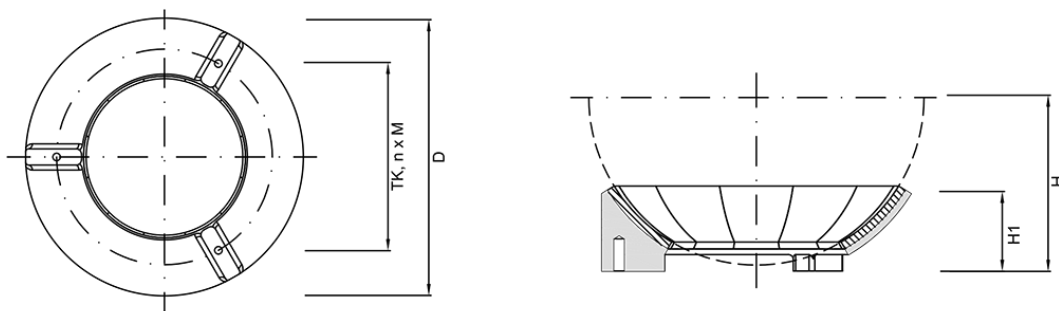

KST...vessel holders

for cylindrical vessel [DN]	for spherical vessel [l]	D [mm]	H [mm]	H1 [mm]	TK [mm]	n x M	Order number
400		383	215	105	340	3 x Ø14	KST 400
450	50	429	240/255	115	395	3 x Ø14	KST 450/50
600	100	515	315/310	125	400	3 x Ø14	KST 600/100
	200	615	360	125	585	3 x Ø14	KST 200

SADDLE SUPPORTS

Saddle supports are used mostly to hold up horizontal containers, such as separators or shell and tube heat exchangers, and are fixed using flange rings. They are made of stainless steel and can be used with a nominal diameter of 150 both in the PF and KF systems. During assembly it should be ensured that only one saddle support is used as an anchor point; the second should be mounted as an expansion point to prevent unauthorised tension in the glass.

Description:	Item number	Examples
Saddle supports	KSA DN	KSA 150
Saddle supports, for silumin clamp rings	KSA DN-O4	KSA 150-O4

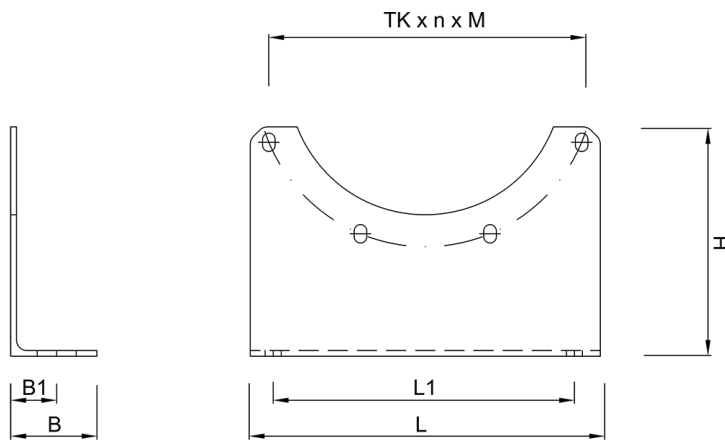

KSA...saddle support

Nominal diameter [DN]	L [mm]	L1	H [mm]	B [mm]	B1 [mm]	TK [mm]	nxM	Item no.
150	305	263	200	75	40	240 ¹⁾ 254 ²⁾	4xØ11 3xØ11	KSA 150
200	305	263	200	75	40	295	4xØ11	KSA 200
300	320	280	180	75	40	400	4xØ11	KSA 300
400	380	320	190	75	40	495	5xØ11	KSA 400
450	405	320	225	112,5	57	585	4xØ11	KSA 450
600	590	500	275	115	57	710	6xØ16	KSA 600

1) Pitch circle for PF system, 2) Pitch circle for KF system

LIFTING LUGS

Lifting lugs are attached to horizontal containers in order to move them using appropriate lifting equipment and transport them to their place of installation. They are made of stainless steel and can be used with a nominal diameter of 150 both in the PF and KF systems.

Description:

Lifting lugs, for silumin clamp rings

Item number

KLL DN-O4

Examples

KLL 300-O4

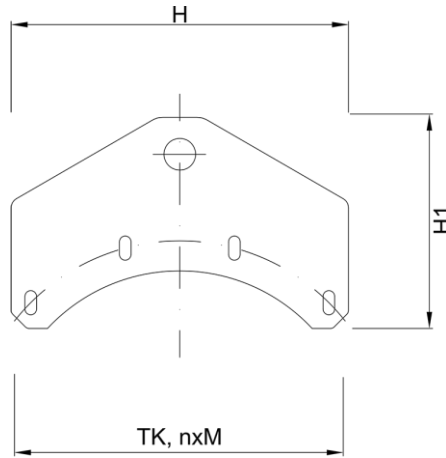

KLL... Lifting lug

Nominal diameter [DN]	H [mm]	H1 [mm]	TK [mm]	NxM	Item no.
150	245	180	240 ¹⁾	4xØ9	KLL 150
			254 ²⁾	4xØ9	
200	305	200	295	4xØ11	KLL 200
300	320	200	400	4xØ11	KLL 300
400	405	204	495	4xØ11	KLL 400
450	405	204	285	4xØ11	KLL 450
600	590	250	710	6xØ16	KLL 600

1) Pitch circle for PF system, 2) Pitch circle for KF system

LIFTING AND LOWERING DEVICE

For many applications, e.g. mobile filters and vessels with stirrers, the lowering of components of the apparatus is required. This can be achieved with the lifting and lowering device type KLD. To move the components, the flange connection of the apparatus needs to be opened after which the bottom part of the apparatus can be lowered or lifted with a crank lever. Optionally, a PTFE-jacketed flange connector (Option O6) with an additional support mount can be used to fixate the apparatus' top part. For frequent opening and closing processes the use of a gasket type CGP is recommended. The device's standard stroke length is 600 mm but can be modified according to the requirements. An adjustable stopper can also be used to restrict the movement.

Additional options for the lifting and lowering device are a sideways swinging mechanism (Option O7), stainless steel fittings (Option O8) as well as a crank lever with an angular gear (Option O9).

For requirements varying from our standards please contact our technical department.

Product name:

- Lifting and lowering device
- Lifting and lowering device with PTFE-jacketed counter flange
- Lifting and lowering device swinging mechanism (L1 + 10mm)
- Lifting and lowering device, with stainless steel fittings
- Lifting and lowering device, with angular gear crank lever

Item number

- KLD DN
- KLD DN-O6
- KLD DN-O7
- KLD DN-O8
- KLD DN-O9

Examples

- KLD 300
- KLD 300-O6
- KLD 300-O7
- KLD 300-O8
- KLD 300-O9

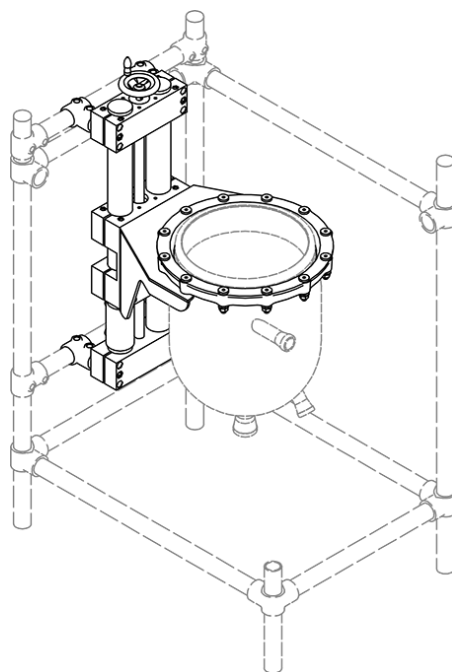
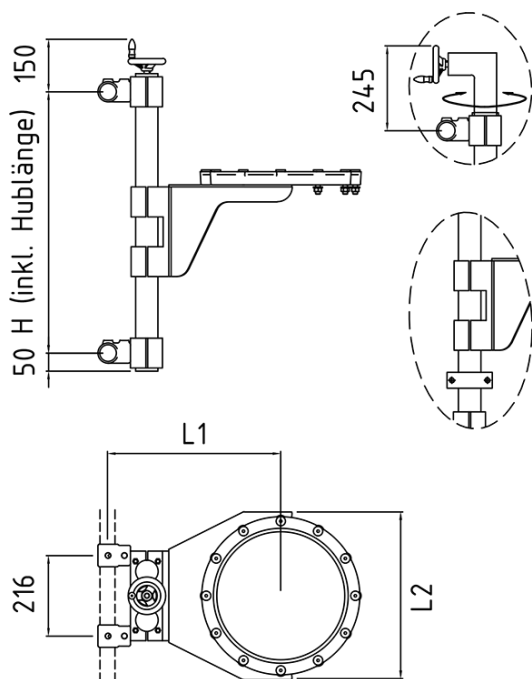

Lifting and lowering device KLD...

For cylindrical vessel	Volume	Max. load	L1	L2	Stroke	H	Item no.
[DN]	[l]	[kg]	[mm]	[mm]	[mm]	[mm]	
200	10-20	150	410	350	600	925	KLD 200
300	30-50	180	460	450	600	925	KLD 300
400	50-100	220	500	550	600	925	KLD 400
450	50-100	250	575	630	600	925	KLD 450

More options and special products are listed below. For details or special requirements, please contact our technical departments.

MACROLON COVERINGS

For further protection of the operating personnel Makrolon coverings can be useful in glass plants at critical points. These are connected to the frame and act as a splitter and spray protection. For easy access to certain parts of the plant Makrolon coverings can be carried out with closable openings or moveable.

WELDED FRAMES

For larger loads, for instance as a supporting structure and fixed-point mounting of larger nominal size columns, or for special applications, such as supporting structures for clean room applications, individual welded frames can be delivered. For this, there are already some concepts available that can be configured individually according to customer requirements and project specifications.

MOBILE RACKS FOR RAIL SYSTEMS

For frequent planned replacements of one or more specific sections in columns there is a concept of a castor / rail system.

For rail systems in autoclave mobile welding racks adapted to the customer's situations can be delivered.

OPTIONS STRUCTURES

For framework structural components the following options can be chosen in addition to the standard structural components. Each option chosen must be entered at the end of the item number. Several options can be chosen and they are presented as far as possible in alphabetical order. In the following table you will find examples of item numbering for additional options.

Product description:	Item number	Examples
90° corner joint type 10, 1", blue lacquer	type KKØ _{tube} -O1	KK 10-6-O1
Swivel castor with brake, electrically conductive design	KC Ø _{tube} -M1-O1	KC 7-M1-O1
Saddle support, for silumin clamp rings	KSA DN-O4	KSA 150-O4

You can choose from the following options:

OPTION C – COATING

Steel structure fittings without a coating are used as the standard design. Fittings with a blue lacquer are optionally available.

C = blue lacquer

OPTION M – MATERIAL

The following additional materials can be chosen:

M1 = electrically conductive castor design to protect against electrostatic discharge

M2 = steel design, for items which have a stainless steel standard design

M3 = steel design, galvanised, for items which have a stainless steel standard design

OPTION O – SPECIAL OPTIONS

The following options are offered for certain structural components.

O1 = swivel castor

O2 = fixed castor

O3Ø_{tube}= installation kit for lower support ring incl. structure fittings, insert bushes and screw set

O4 = designed with bores for silumin clamp rings where this is not provided in the standard design (for saddle supports and lifting lugs)

O5 = with a connection for ¾" tube (for support brackets)